

LO-COG® DC Servo Motors



Pittman brand LO-COG® brush-commutated DC motors offer smooth, quiet operation and long life. Armatures are skewed to minimize magnetic cogging, even at low speeds, and windings are resin impregnated for greater reliability in incremental motion applications. An innovative cartridge brush assembly reduces audible and electrical noise and significantly improves brush life by maintaining optimum brush force throughout the life of the motor. For precision motor control, Hewlett-Packard® optical encoders are available in 2 or 3 channel versions with several CPR ranges to meet your position, velocity and direction feedback needs.

Construction

- 2 pole permanent magnet stators are constructed of ceramic magnets enclosed in heavy-gauge steel return rings
- Diamond turned commutators ensure maximum brush life
- Standard copper graphite brushes
- Precision ground hardened stainless steel shafts
- Silicon-steel laminations
- Self-aligning, sintered bronze bearings

Options

- Custom cables
- Multiple shaft configurations
- Shaft-mounted pulleys and gears
- Ball bearings
- Multiple windings
- Electromechanical brakes
- Integrated Hewlett-Packard® optical encoders
- Adaptors available for other encoders
- RFI suppression
- Dynamic armature balancing
- Customized versions available in production quantities
- Other brush materials available

Series 8000

- Available in 3 lengths
- 7 slot armature
- Speeds from 7,700 to 10,650 RPM
- Peak Torques from 5.05 to 16.8 oz-in
- Encoder resolutions from 96 to 1024

Series 9000

- Available in 6 lengths
- 7 slot armature
- Speeds from 4,900 to 8,250 RPM
- Peak Torques from 8.35 to 77 oz-in
- Encoder resolutions from 96 to 2048

Series 14000

- Available in 7 lengths
- 11 slot armature
- Speeds from 3,050 to 4,230 RPM
- Peak Torques from 62.8 to 410 oz-in
- Encoder resolutions from 96 to 2048

Motor Data

Line No.	Parameter	Symbol	Units	8X12	8X22	8X13	8X23	8X14	8X24
1	Continuous Torque (Max.) ¹	T _C	oz-in (N-m)	1.3 (8.90 X 10 ⁻³)	1.6 (11.2 X 10 ⁻³)	1.5 (10.7 X 10 ⁻³)	2.0 (14.1 X 10 ⁻³)	2.1 (14.5 X 10 ⁻³)	2.6 (18.5 X 10 ⁻³)
2	Peak Torque (Stall) ²	T _{PK}	oz-in (N-m)	5.1 (35.7 X 10 ⁻³)	7.4 (52.0 X 10 ⁻³)	6.8 (47.7 X 10 ⁻³)	10.5 (74.2 X 10 ⁻³)	11.9 (84.0 X 10 ⁻³)	16.8 (118.6 X 10 ⁻³)
3	Motor Constant	K _M	oz-in/√W (N-m/√W)	0.93 (6.6 X 10 ⁻³)	1.12 (7.9 X 10 ⁻³)	1.05 (7.4 X 10 ⁻³)	1.30 (9.2 X 10 ⁻³)	1.22 (8.6 X 10 ⁻³)	1.49 (10.5 X 10 ⁻³)
4	No-Load Speed	S _{NL}	rpm (rad/s)	7729 (809)	7847 (822)	8238 (863)	8298 (869)	10648 (1113)	10158 (1064)
5	Friction Torque	T _F	oz-in (N-m)	0.35 (2.5 X 10 ⁻³)	0.35 (2.5 X 10 ⁻³)	0.35 (2.5 X 10 ⁻³)	0.35 (2.5 X 10 ⁻³)	0.35 (2.5 X 10 ⁻³)	0.35 (2.5 X 10 ⁻³)
6	Rotor Inertia	J _M	oz-in-s ² (kg-m ²)	1.3 X 10 ⁻⁴ (9.18 X 10 ⁻⁷)	1.4 X 10 ⁻⁴ (9.89 X 10 ⁻⁷)	1.6 X 10 ⁻⁴ (1.13 X 10 ⁻⁶)	1.7 X 10 ⁻⁴ (1.20 X 10 ⁻⁶)	2.2 X 10 ⁻⁴ (1.55 X 10 ⁻⁶)	2.3 X 10 ⁻⁴ (1.62 X 10 ⁻⁶)
7	Electrical Time Constant	τ _E	ms	0.50	0.52	0.48	0.55	0.54	0.54
8	Mechanical Time Constant	τ _M	ms	21.5	15.6	21.0	14.1	21.0	14.7
9	Viscous Damping— Infinite Source Impedance	D	oz-in/krpm (N-m/(rad/s))	0.0087 (5.87 X 10 ⁻⁷)	0.0153 (1.03 X 10 ⁻⁶)	0.0104 (7.01 X 10 ⁻⁷)	0.0176 (1.19 X 10 ⁻⁶)	0.0147 (9.91 X 10 ⁻⁷)	0.0202 (1.36 X 10 ⁻⁶)
10	Viscous Damping— Zero Source Impedance	K _D	oz-in/krpm (N-m/(rad/s))	0.64 (4.32 X 10 ⁻⁵)	0.92 (6.20 X 10 ⁻⁵)	0.81 (5.46 X 10 ⁻⁵)	1.25 (8.42 X 10 ⁻⁵)	1.10 (7.42 X 10 ⁻⁵)	1.63 (1.10 X 10 ⁻⁴)
11	Maximum Winding Temperature	θ _{MAX}	°F (°C)	311 (155)	311 (155)	311 (155)	311 (155)	311 (155)	311 (155)
12	Thermal Impedance	R _{TH}	°F/watt °C/watt	75.9 (24.4)	75.9 (24.4)	72.9 (22.7)	72.9 (22.7)	70.52 (21.4)	70.52 (21.4)
13	Thermal Time Constant	τ _{TH}	min	7.75	7.75	9.00	9.00	10.70	10.70
14	Motor Weight	W _M	oz (gm)	4.49 (127.3)	4.69 (133.0)	4.86 (137.8)	5.05 (143.2)	5.62 (159.3)	5.81 (164.7)
15	Motor Length, 82XX	L ₁	in max (mm max)	2.070 (52.6)	2.070 (52.6)	2.195 (54.61)	2.195 (54.61)	2.445 (62.1)	2.445 (62.1)
16	Motor Length, 83XX/84XX	L ₁	in max (mm max)	2.007 (51)	2.007 (51)	2.132 (54.2)	2.132 (54.2)	2.382 (60.5)	2.382 (60.5)

¹Continuous torque specified at 25°C ambient temperature and without additional heat sink.

²Theoretical values supplied for reference only.

Model 8XX2 Winding Data (Other windings available upon request)

Line No.	Parameter	Symbol	Units	8X12				8X22			
17	Reference Voltage	E	V	12.0	19.1	24.0	30.3	12.0	19.1	24.0	30.3
18	Torque Constant	K_T	oz-in/A (N-m/A)	1.94 (13.7×10^{-3})	3.06 (21.7×10^{-3})	3.87 (27.3×10^{-3})	4.89 (34.6×10^{-3})	1.94 (13.7×10^{-3})	3.07 (21.7×10^{-3})	3.88 (27.4×10^{-3})	4.88 (34.5×10^{-3})
19	Back-EMF Constant	K_E	V/krpm (V/rad/s)	1.43 (13.7×10^{-3})	2.27 (21.7×10^{-3})	2.86 (27.3×10^{-3})	3.62 (34.6×10^{-3})	1.43 (13.7×10^{-3})	2.27 (21.7×10^{-3})	2.87 (27.4×10^{-3})	3.61 (34.5×10^{-3})
20	Resistance	R_T	Ω	4.38	10.80	17.20	27.3	3.10	7.61	12.1	19.1
21	Inductance	L	mH	2.15	5.40	8.62	13.8	1.57	3.93	6.27	9.92
22	No-Load Current	I_{NL}	A	0.22	0.14	0.11	0.09	0.25	0.16	0.12	0.10
23	Peak Current (Stall)	I_p	A	2.74	1.76	1.40	1.11	3.88	2.51	1.99	1.59

Model 8XX3 Winding Data (Other windings available upon request)

Line No.	Parameter	Symbol	Units	8X13				8X23			
24	Reference Voltage	E	V	12.0	19.1	24.0	30.3	12.0	19.1	24.0	30.3
25	Torque Constant	K_T	oz-in/A (N-m/A)	1.85 (13.1×10^{-3})	2.95 (20.8×10^{-3})	3.70 (26.1×10^{-3})	4.67 (33.0×10^{-3})	1.88 (13.3×10^{-3})	2.94 (20.8×10^{-3})	3.73 (26.4×10^{-3})	4.71 (33.3×10^{-3})
26	Back-EMF Constant	K_E	V/krpm (V/rad/s)	1.37 (13.1×10^{-3})	2.18 (20.8×10^{-3})	2.73 (26.1×10^{-3})	3.45 (33.0×10^{-3})	1.39 (13.3×10^{-3})	2.18 (20.8×10^{-3})	2.76 (26.4×10^{-3})	3.48 (33.3×10^{-3})
27	Resistance	R_T	Ω	3.20	7.94	12.5	19.8	2.17	5.20	8.24	13.1
28	Inductance	L	mH	1.48	3.78	5.93	9.46	1.17	2.85	4.57	7.29
29	No-Load Current	I_{NL}	A	0.24	0.15	0.12	0.09	0.27	0.17	0.13	0.11
30	Peak Current (Stall)	I_p	A	3.75	2.40	1.92	1.53	5.54	3.67	2.91	2.32

Model 8XX4 Winding Data (Other windings available upon request)

Line No.	Parameter	Symbol	Units	8X14				8X24			
31	Reference Voltage	E	V	12.0	19.1	24.0	30.3	12.0	19.1	24.0	30.3
32	Torque Constant	K_T	oz-in/A (N-m/A)	1.46 (10.3×10^{-3})	2.31 (16.3×10^{-3})	2.92 (20.6×10^{-3})	3.69 (26.1×10^{-3})	1.54 (10.9×10^{-3})	2.47 (17.5×10^{-3})	3.09 (21.9×10^{-3})	3.86 (27.3×10^{-3})
33	Back-EMF Constant	K_E	V/krpm (V/rad/s)	1.08 (10.3×10^{-3})	1.71 (16.3×10^{-3})	2.16 (20.6×10^{-3})	2.73 (26.1×10^{-3})	1.14 (10.9×10^{-3})	1.83 (17.5×10^{-3})	2.29 (21.9×10^{-3})	2.86 (27.3×10^{-3})
34	Resistance	R_T	Ω	1.52	3.64	5.73	9.06	1.17	2.79	4.33	6.75
35	Inductance	L	mH	0.77	1.94	3.10	4.95	0.58	1.50	2.34	3.65
36	No-Load Current	I_{NL}	A	0.35	0.22	0.18	0.14	0.36	0.23	0.18	0.15
37	Peak Current (Stall)	I_p	A	7.90	5.24	4.19	3.34	10.3	6.85	5.54	4.49

Model 8X12

Motor Speed & Current vs. Torque
(24V Winding)

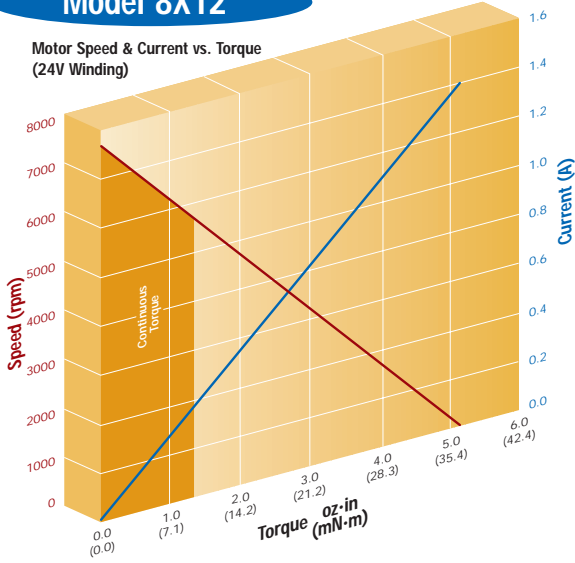

Model 8X22

Motor Speed & Current vs. Torque
(24V Winding)

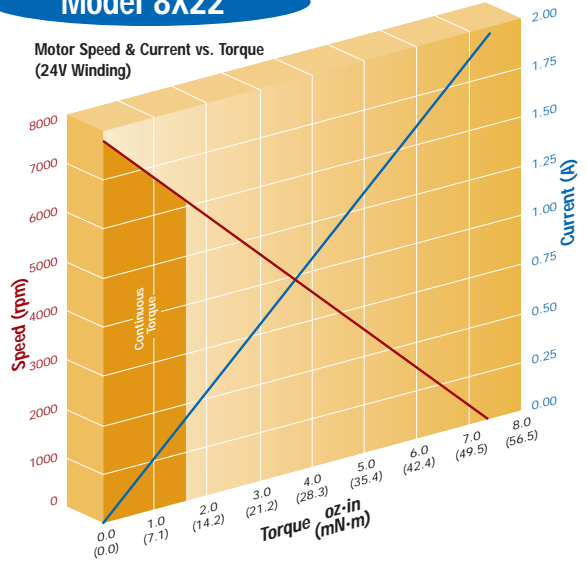

Model 8X13

Motor Speed & Current vs. Torque
(24V Winding)

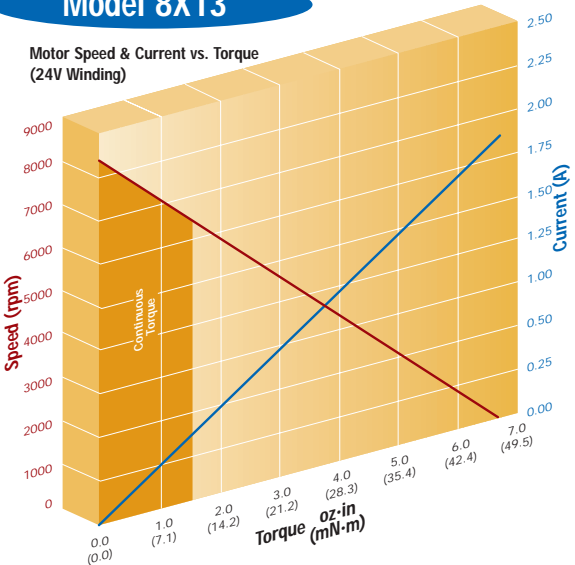

Model 8X23

Motor Speed & Current vs. Torque
(24V Winding)

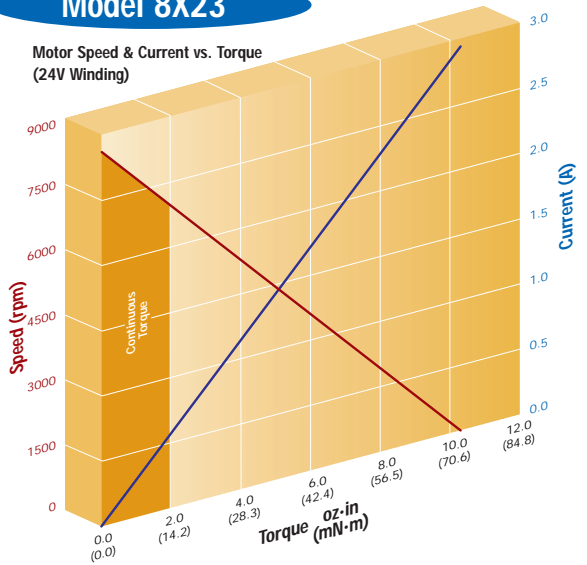

Model 8X14

Motor Speed & Current vs. Torque
(24V Winding)

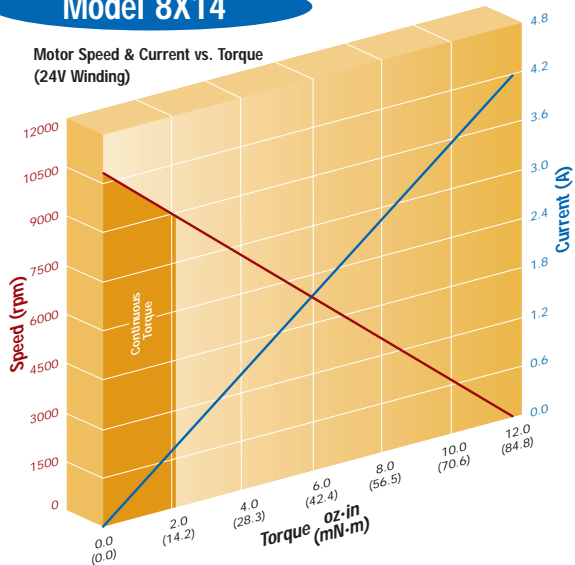

Model 8X24

Motor Speed & Current vs. Torque
(24V Winding)

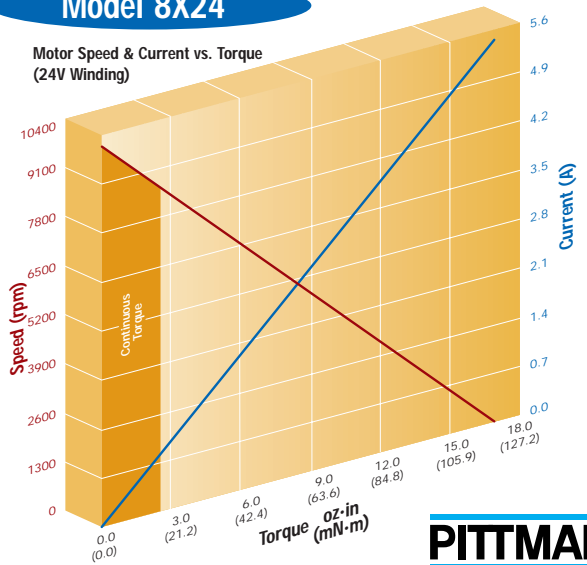

81XX Motor

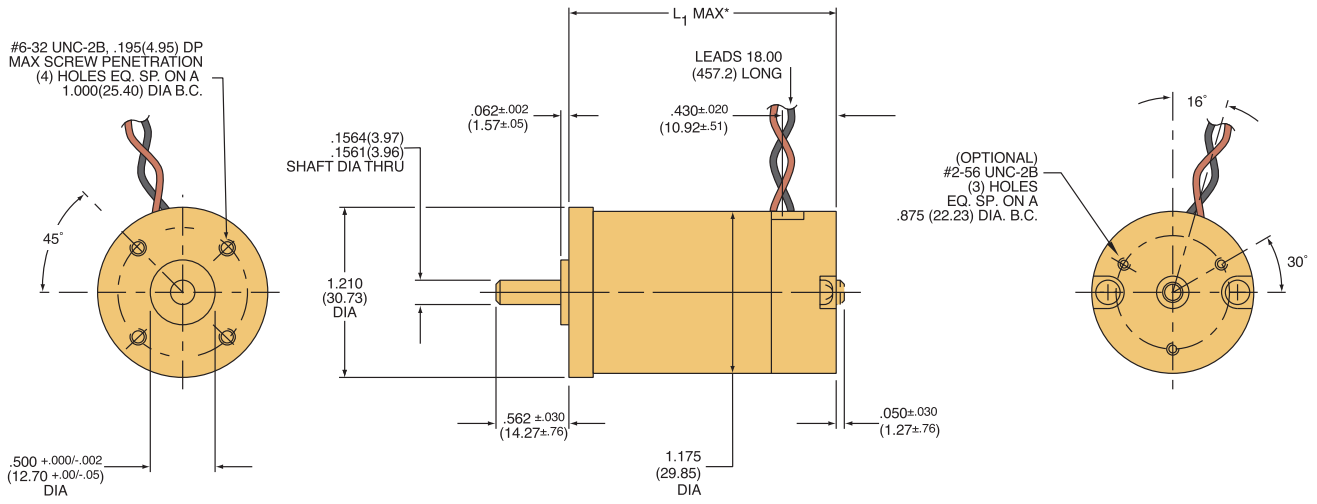

82XX Motor

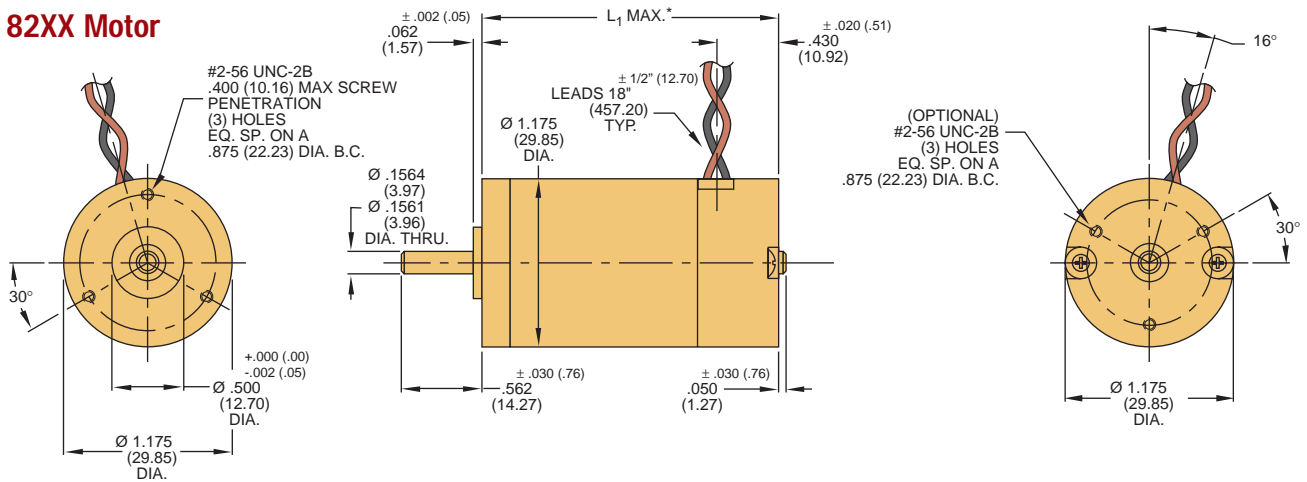

Notes:

- Unless otherwise specified, all tolerances are to be ±.005 (.01)
- All measurements are in inches (mm)
- *See line number 15 and 16 in the motor data chart

83XX Motor

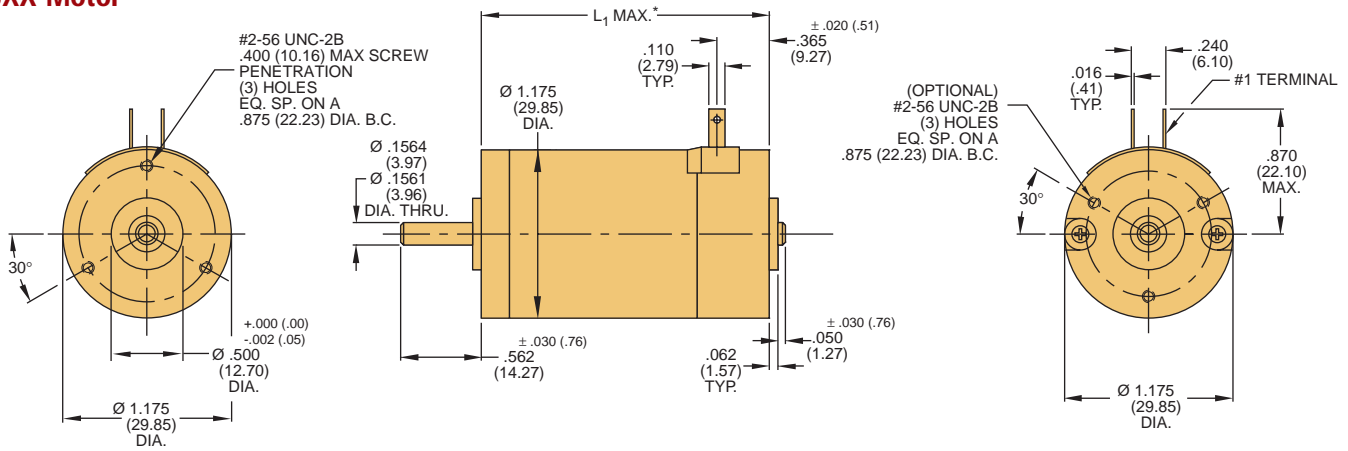

84XX Motor

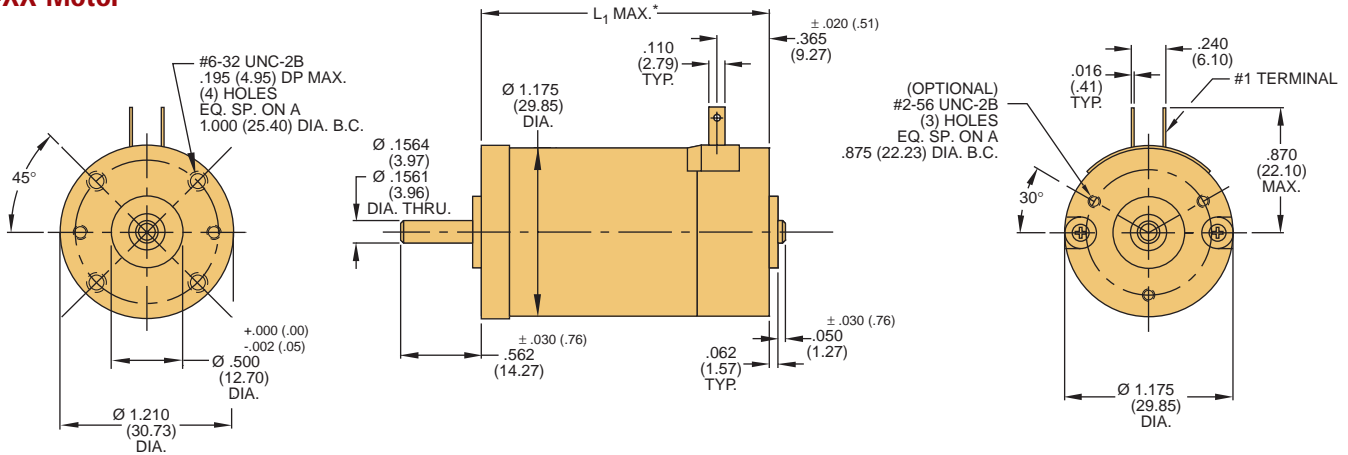

Encoder Connection Chart

Pin No.	Color	Connection
1	Black	Ground
2	Green	Index/NC
3	Yellow	Channel A
4	Red	Vcc
5	Blue	Channel B

Notes:

- Unless otherwise specified, all tolerances are to be $\pm .005$ (.01)
- All measurements are in inches (mm)
- *See line number 15 and 16 in the motor data chart

82XX Motor with 91X0 Encoder

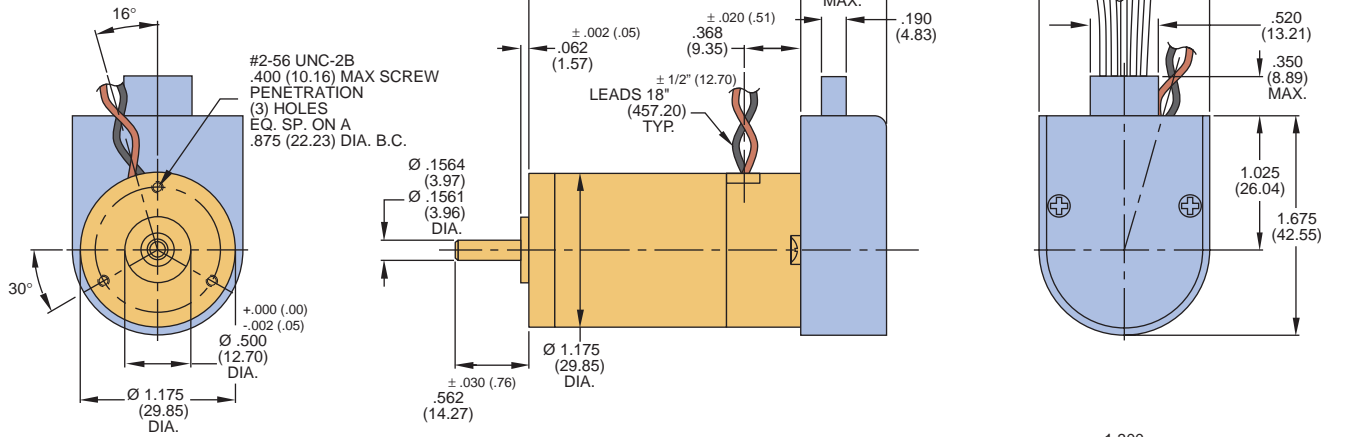

83XX Motor with 91X0 Encoder

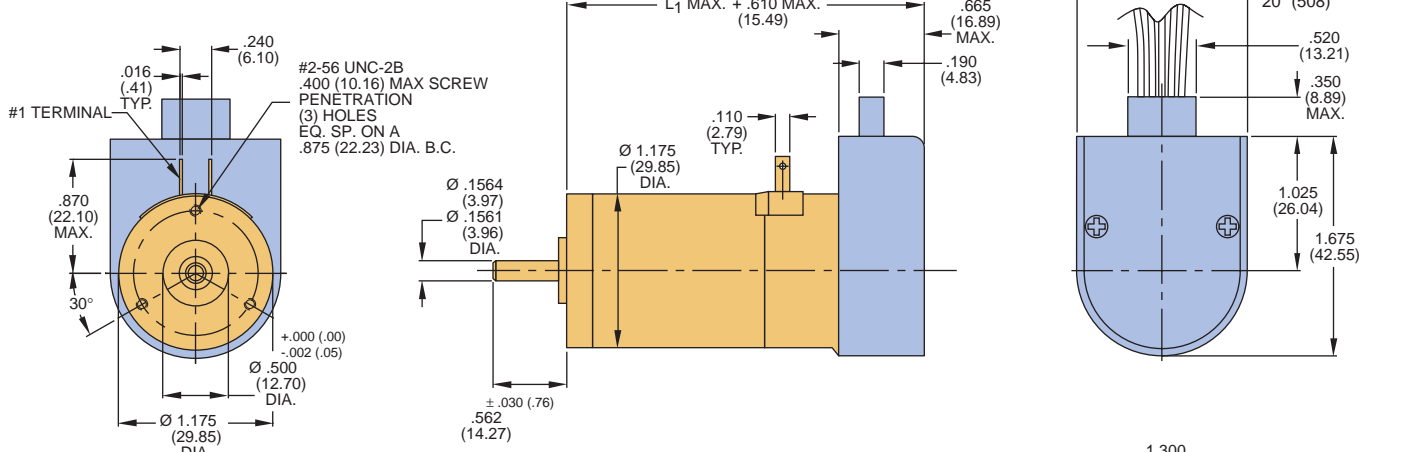

84XX Motor with 91X0 Encoder

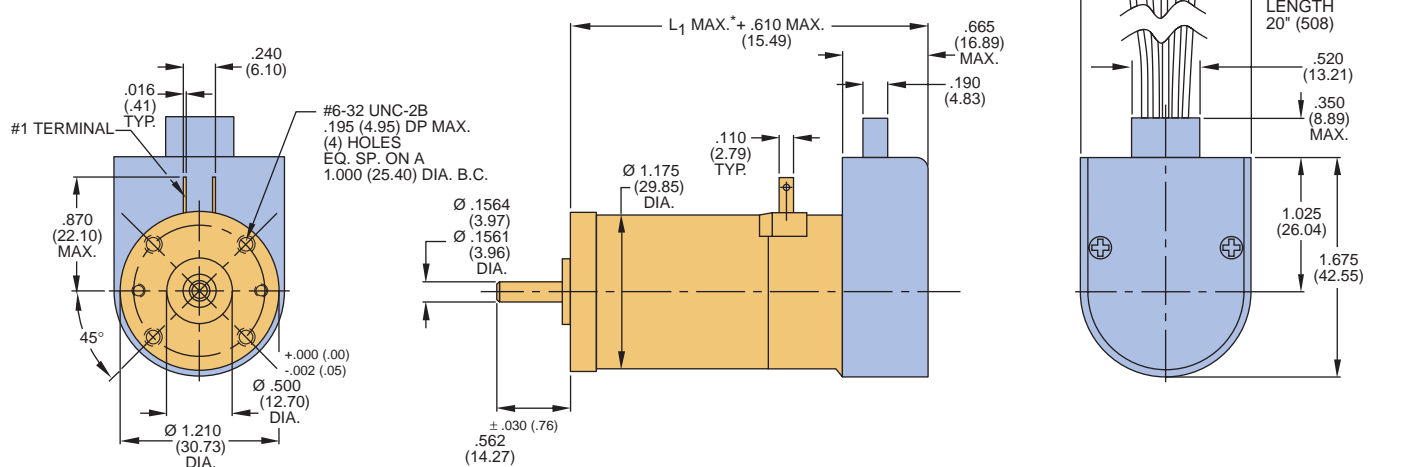

Motor Data

Line No.	Parameter	Symbol	Units	9X12	9X32	9X13	9X33	9X14	9X34	9X35	9X36	9X37
1	Continuous Torque (Max.) ¹	T _C	oz-in (N-m)	1.6 (11.2 X 10 ⁻³)	2.3 (16.2 X 10 ⁻³)	3.2 (22.6 X 10 ⁻³)	4.7 (33.2 X 10 ⁻³)	3.9 (27.8 X 10 ⁻³)	6.1 (43.1 X 10 ⁻³)	6.9 (48.7 X 10 ⁻³)	9.5 (67.1 X 10 ⁻³)	11.5 (81.2 X 10 ⁻³)
2	Peak Torque (Stall) ²	T _{PK}	oz-in (N-m)	8.4 (59.0 X 10 ⁻³)	13.8 (97.5 X 10 ⁻³)	15.6 (110.2 X 10 ⁻³)	31.6 (223.2 X 10 ⁻³)	23.9 (168.8 X 10 ⁻³)	41.3 (291.7 X 10 ⁻³)	49.4 (348.9 X 10 ⁻³)	61.8 (436.4 X 10 ⁻³)	77.0 (543.8 X 10 ⁻³)
3	Motor Constant	K _M	oz-in/√W (N-m/√W)	1.16 (8.2 X 10 ⁻³)	1.62 (11.4 X 10 ⁻³)	1.94 (13.7 X 10 ⁻³)	2.66 (18.8 X 10 ⁻³)	2.05 (14.5 X 10 ⁻³)	3.01 (21.3 X 10 ⁻³)	3.21 (22.7 X 10 ⁻³)	4.11 (29.0 X 10 ⁻³)	4.41 (31.1 X 10 ⁻³)
4	No-Load Speed	S _{NL}	rpm (rad/s)	8251 (864.1)	7015 (734.6)	5592 (585.6)	5993 (627.6)	7666 (802.8)	6151 (644.2)	5348 (560.1)	4916 (514.8)	5331 (558.3)
5	Friction Torque	T _F	oz-in (N-m)	0.4 (2.8 X 10 ⁻³)	0.5 (3.5 X 10 ⁻³)	0.5 (3.5 X 10 ⁻³)	0.6 (4.2 X 10 ⁻³)	0.5 (3.5 X 10 ⁻³)	0.6 (4.2 X 10 ⁻³)	0.65 (4.6 X 10 ⁻³)	0.8 (5.6 X 10 ⁻³)	0.80 (5.6 X 10 ⁻³)
6	Rotor Inertia	J _M	oz-in-s ² (kg-m ²)	2.2 X 10 ⁻⁴ (1.55 X 10 ⁻⁶)	2.7 X 10 ⁻⁴ (1.91 X 10 ⁻⁶)	3.9 X 10 ⁻⁴ (2.75 X 10 ⁻⁶)	4.6 X 10 ⁻⁴ (3.25 X 10 ⁻⁶)	5.4 X 10 ⁻⁴ (3.81 X 10 ⁻⁶)	5.9 X 10 ⁻⁴ (4.17 X 10 ⁻⁶)	7.9 X 10 ⁻⁴ (5.58 X 10 ⁻⁶)	1.0 X 10 ⁻³ (7.06 X 10 ⁻⁶)	1.2 X 10 ⁻³ (8.47 X 10 ⁻⁶)
7	Electrical Time Constant	τ _E	ms	0.53	0.63	0.74	0.84	0.80	0.85	0.00	1.06	1.06
8	Mechanical Time Constant	τ _M	ms	22.8	14.4	14.7	9.29	18.1	9.25	10.9	8.5	8.88
9	Viscous Damping— Infinite Source Impedance	D	oz-in/krpm (N-m/rad/s)	0.0086 (5.79 X 10 ⁻⁷)	0.0272 (1.83 X 10 ⁻⁶)	0.0113 (7.62 X 10 ⁻⁷)	0.0335 (2.25 X 10 ⁻⁶)	0.0125 (8.43 X 10 ⁻⁷)	0.0387 (2.61 X 10 ⁻⁶)	0.0450 (3.03 X 10 ⁻⁶)	0.0525 (3.54 X 10 ⁻⁶)	0.0550 (3.71 X 10 ⁻⁶)
10	Viscous Damping— Zero Source Impedance	K _D	oz-in/krpm (N-m/rad/s)	1.00 (6.74 X 10 ⁻⁵)	1.94 (1.31 X 10 ⁻⁴)	2.78 (1.87 X 10 ⁻⁴)	5.23 (3.53 X 10 ⁻⁴)	3.11 (2.09 X 10 ⁻⁴)	6.68 (4.50 X 10 ⁻⁴)	7.6 (5.12 X 10 ⁻⁴)	12.5 (8.42 X 10 ⁻⁴)	14.4 (9.71 X 10 ⁻⁴)
11	Maximum Winding Temp.	θ _{MAX}	°F (°C)	311 (155)	311 (155)	311 (155)	311 (155)	311 (155)	311 (155)	311 (155)	311 (155)	311 (155)
12	Thermal Impedance	R _{TH}	°F/watt °C/watt	72.9 (22.7)	72.9 (22.7)	66.4 (19.1)	66.4 (19.1)	62.8 (17.1)	62.8 (17.1)	58.5 (14.7)	56.3 (13.5)	52.16 (11.2)
13	Thermal Time Constant	τ _{TH}	min	7.21	7.21	11.1	11.1	12.0	12.0	12.9	13.5	13.8
14	Motor Weight	W _M	oz (gm)	6.96 (197.3)	6.98 (197.9)	8.98 (254.6)	8.90 (252.3)	10.1 (286.3)	10.1 (286.3)	0.0 (TBD)	13.8 (391.2)	15.5 (439.4)
15	Motor Length, 92XX, 94XX	L ₁	in max (mm max)	1.828 (46.4)	1.828 (46.4)	2.203 (56.0)	2.203 (56.0)	2.403 (61.0)	2.403 (61.0)	2.703 (69.0)	3.053 (78.0)	3.353 (85.17)

Model 9XX2 Winding Data (Other windings available upon request)

Line No.	Parameter	Symbol	Units	9X12				9X32			
				12.0	19.1	24.0	30.3	12.0	19.1	24.0	30.3
16	Reference Voltage	E	V	12.0	19.1	24.0	30.3	12.0	19.1	24.0	30.3
17	Torque Constant	K _T	oz-in/A (N-m/A)	1.86 (13.2 X 10 ⁻³)	2.95 (20.8 X 10 ⁻³)	3.72 (26.3 X 10 ⁻³)	4.68 (33.1 X 10 ⁻³)	2.20 (15.6 X 10 ⁻³)	3.50 (24.7 X 10 ⁻³)	4.40 (31.1 X 10 ⁻³)	5.53 (39.1 X 10 ⁻³)
18	Back-EMF Constant	K _E	V/krpm (V/rad/s)	1.38 (13.2 X 10 ⁻³)	2.18 (20.8 X 10 ⁻³)	2.75 (26.3 X 10 ⁻³)	3.46 (33.1 X 10 ⁻³)	1.63 (15.6 X 10 ⁻³)	2.59 (24.7 X 10 ⁻³)	3.25 (31.1 X 10 ⁻³)	4.09 (39.1 X 10 ⁻³)
19	Resistance	R _T	Ω	2.63	6.45	10.2	16.1	1.93	4.70	7.38	11.6
20	Inductance	L	mH	1.35	3.40	5.42	8.56	1.16	2.94	4.64	7.34
21	No-Load Current	I _{NL}	A	0.26	0.16	0.13	0.10	0.32	0.20	0.16	0.13
22	Peak Current (Stall)	I _P	A	4.56	2.96	2.35	1.88	6.22	4.06	3.25	2.60

¹Continuous torque specified at 25°C ambient temperature and without additional heat sink.

²Theoretical values supplied for reference only.

Model 9XX3 Winding Data (Other windings available upon request)

Line No.	Parameter	Symbol	Units	9X13				9X33			
23	Reference Voltage	E	V	12.0	19.1	24.0	30.3	12.0	19.1	24.0	30.3
24	Torque Constant	K_T	oz-in/A (N-m/A)	2.80 (19.8×10^{-3})	4.47 (31.6×10^{-3})	5.60 (39.5×10^{-3})	7.07 (49.9×10^{-3})	2.67 (18.9×10^{-3})	4.20 (29.7×10^{-3})	5.28 (37.3×10^{-3})	6.68 (47.2×10^{-3})
25	Back-EMF Constant	K_E	V/krpm (V/rad/s)	2.07 (19.8×10^{-3})	3.31 (31.6×10^{-3})	4.14 (39.5×10^{-3})	5.23 (49.9×10^{-3})	1.98 (18.9×10^{-3})	3.10 (29.7×10^{-3})	3.90 (37.3×10^{-3})	4.94 (47.2×10^{-3})
26	Resistance	R_T	Ω	2.17	5.32	8.33	13.2	1.08	2.53	3.94	6.21
27	Inductance	L	mH	1.54	3.93	6.17	9.84	0.84	2.08	3.29	5.27
28	No-Load Current	I_{NL}	A	0.20	0.13	0.10	0.08	0.30	0.19	0.15	0.12
29	Peak Current (Stall)	I_p	A	5.54	3.59	2.88	2.30	11.1	7.55	6.09	4.88

Model 9XX4 Winding Data (Other windings available upon request)

Line No.	Parameter	Symbol	Units	9X14				9X34			
30	Reference Voltage	E	V	12.0	19.1	24.0	30.3	12.0	19.1	24.0	30.3
31	Torque Constant	K_T	oz-in/A (N-m/A)	2.06 (14.5×10^{-3})	3.27 (23.1×10^{-3})	4.13 (29.2×10^{-3})	5.22 (36.9×10^{-3})	2.58 (18.2×10^{-3})	4.07 (28.7×10^{-3})	5.17 (36.5×10^{-3})	6.50 (45.9×10^{-3})
32	Back-EMF Constant	K_E	V/krpm (V/rad/s)	1.53 (14.5×10^{-3})	2.42 (23.1×10^{-3})	3.05 (29.2×10^{-3})	3.86 (36.9×10^{-3})	1.91 (18.2×10^{-3})	3.01 (28.7×10^{-3})	3.82 (36.5×10^{-3})	4.81 (45.9×10^{-3})
33	Resistance	R_T	Ω	1.10	2.59	4.06	6.40	0.83	1.89	2.96	4.62
34	Inductance	L	mH	0.81	2.04	3.25	5.19	0.63	1.56	2.51	3.97
35	No-Load Current	I_{NL}	A	0.29	0.18	0.14	0.11	0.33	0.21	0.16	0.13
36	Peak Current (Stall)	I_p	A	10.9	7.36	5.91	4.73	14.5	10.1	8.11	6.55

Model 9X35/9X36 Winding Data (Other windings available upon request)

Line No.	Parameter	Symbol	Units	9X35				9X36			
37	Reference Voltage	E	V	12.0	19.1	24.0	30.3	12.0	19.1	24.0	30.3
38	Torque Constant	K_T	oz-in/A (N-m/A)	2.47 (17.4×10^{-3})	3.99 (28.2×10^{-3})	4.94 (34.9×10^{-3})	6.27 (44.3×10^{-3})	3.25 (23.0×10^{-3})	5.24 (37.0×10^{-3})	6.49 (45.8×10^{-3})	8.24 (58.2×10^{-3})
39	Back-EMF Constant	K_E	V/krpm (V/rad/s)	1.83 (17.4×10^{-3})	2.95 (28.2×10^{-3})	3.65 (34.9×10^{-3})	3.65 (44.3×10^{-3})	2.4 (23.0×10^{-3})	3.88 (37.0×10^{-3})	4.8 (45.8×10^{-3})	6.09 (58.2×10^{-3})
40	Resistance	R_T	Ω	.68	1.56	2.37	3.72	0.71	1.64	2.49	3.91
41	Inductance	L	mH	TBD	TBD	TBD	TBD	0.66	1.72	2.63	4.24
42	No-Load Current	I_{NL}	A	0.38	0.24	0.19	0.16	0.33	0.20	0.16	0.13
43	Peak Current (Stall)	I_p	A	17.6	12.2	10.1	8.14	16.9	11.7	9.64	7.74

Model 9X37 Winding Data (Other windings available upon request)

Line No.	Parameter	Symbol	Units	9X37			
44	Reference Voltage	E	V	12.0	19.1	24.0	30.3
45	Torque Constant	K_T	oz-in/A (N-m/A)	3.00 (21.2×10^{-3})	4.72 (33.3×10^{-3})	6.00 (42.4×10^{-3})	7.43 (52.5×10^{-3})
46	Back-EMF Constant	K_E	V/krpm (V/rad/s)	2.22 (21.2×10^{-3})	3.49 (33.3×10^{-3})	4.44 (42.4×10^{-3})	5.50 (52.5×10^{-3})
47	Resistance	R_T	Ω	0.55	1.20	1.85	2.82
48	Inductance	L	mH	0.49	1.21	1.97	3.01
49	No-Load Current	I_{NLi}	A	0.37	0.23	0.18	0.15
50	Peak Current (Stall)	I_p	A	21.7	15.9	12.96	10.73

Model 9X12

Motor Speed & Current vs. Torque
(24V Winding)

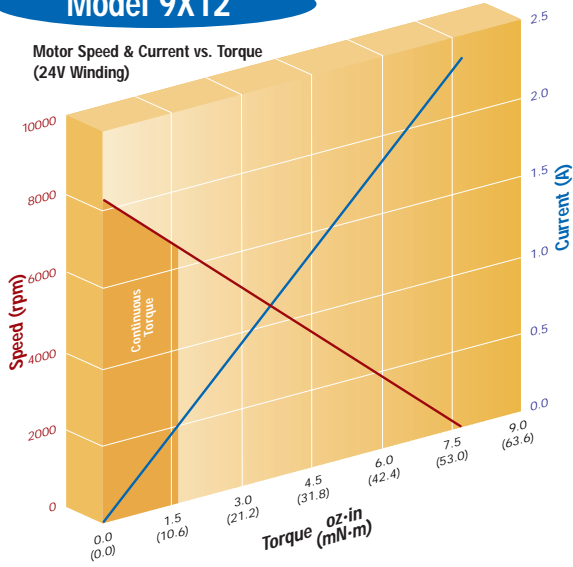

Model 9X14

Motor Speed & Current vs. Torque
(24V Winding)

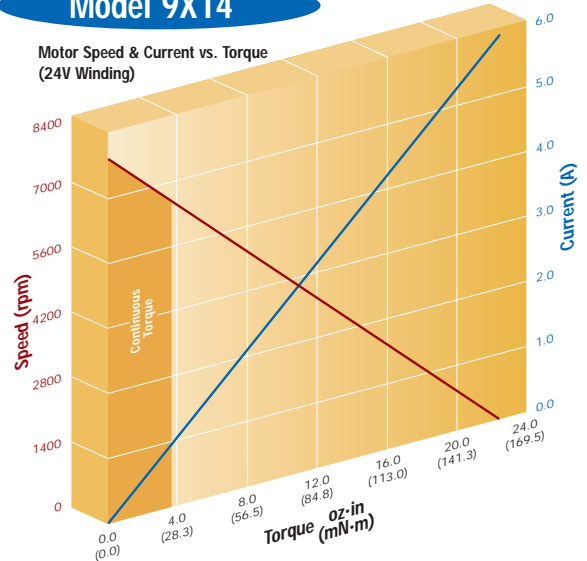

Model 9X13

Motor Speed & Current vs. Torque
(24V Winding)

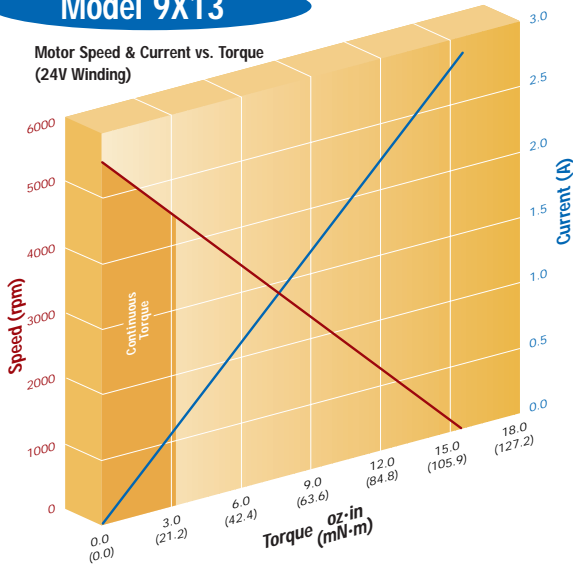

Model 9X32

Motor Speed & Current vs. Torque
(24V Winding)

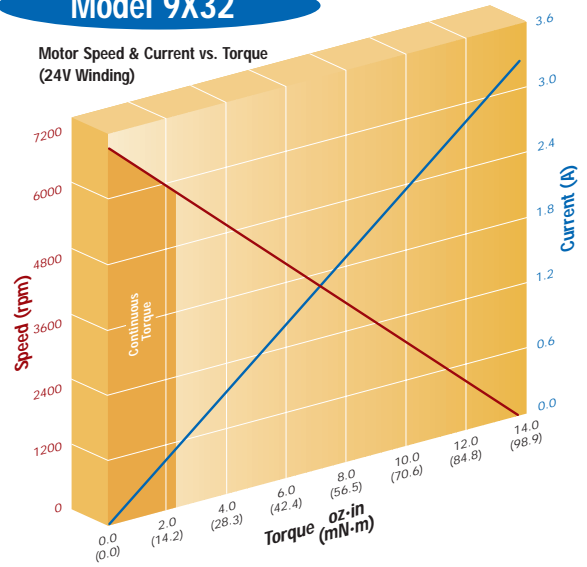

Model 9X33

Motor Speed & Current vs. Torque
(24V Winding)

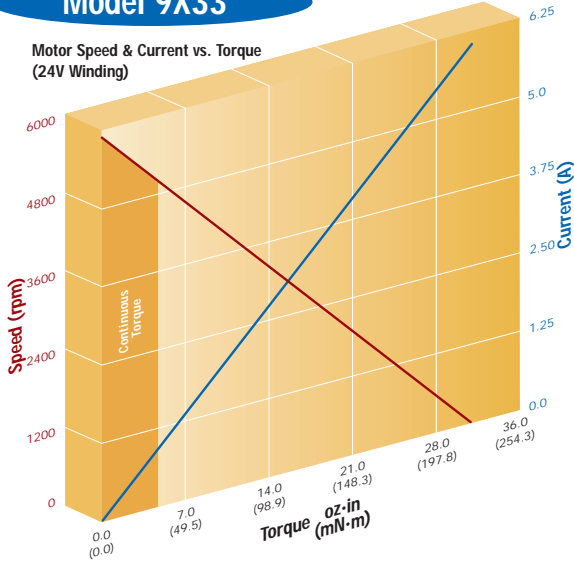

Model 9X35

Motor Speed & Current vs. Torque
(24V Winding)

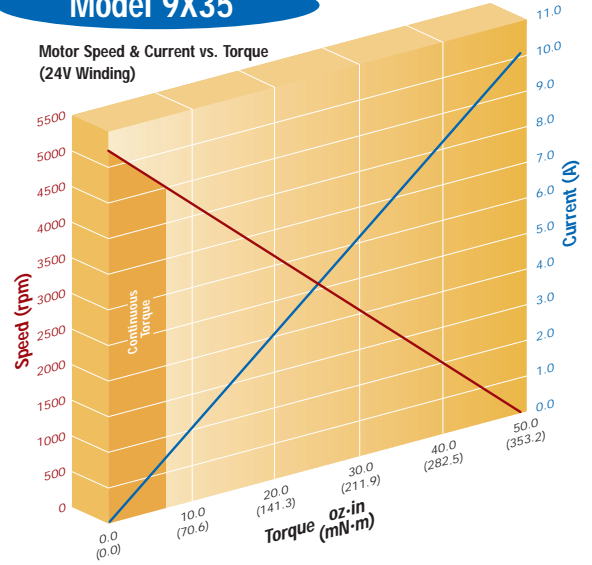

Model 9X34

Motor Speed & Current vs. Torque
(24V Winding)

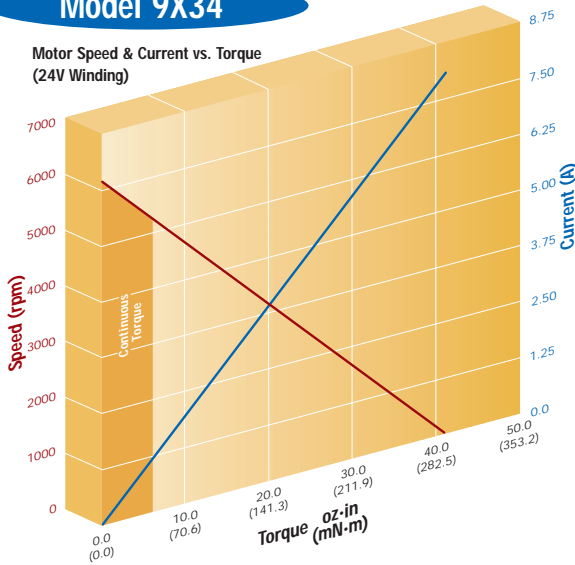

Model 9X36

Motor Speed & Current vs. Torque
(24V Winding)

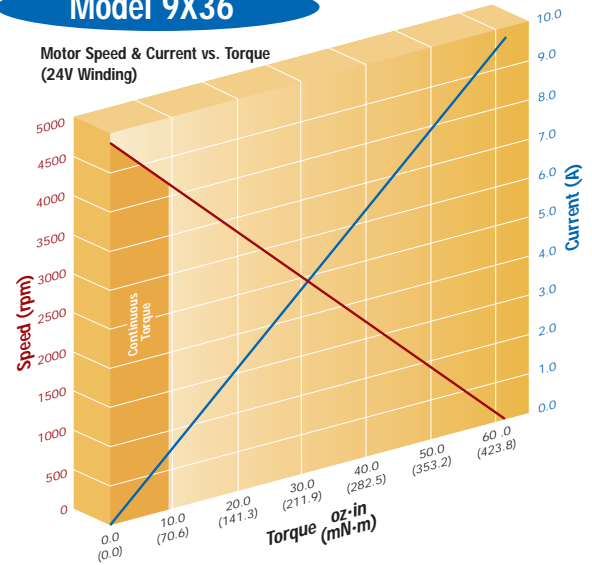

Model 9X37

Motor Speed & Current vs. Torque
(24V Winding)

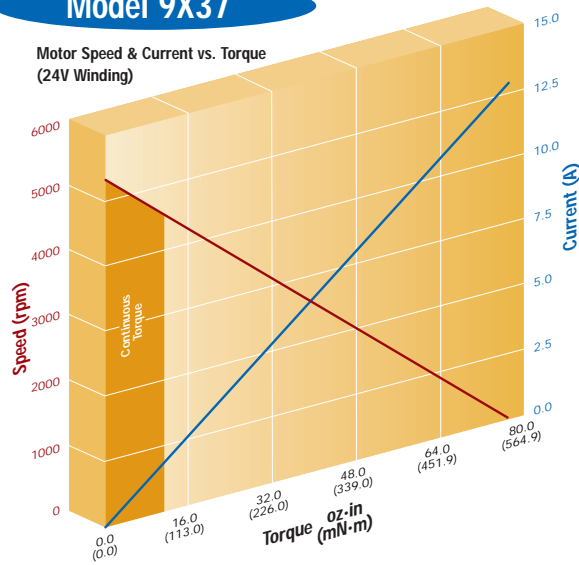

SERIES 9000

94XX Motor

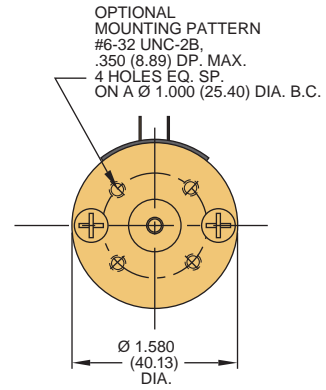
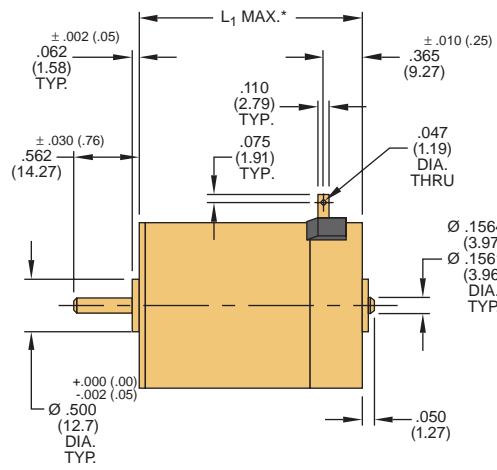
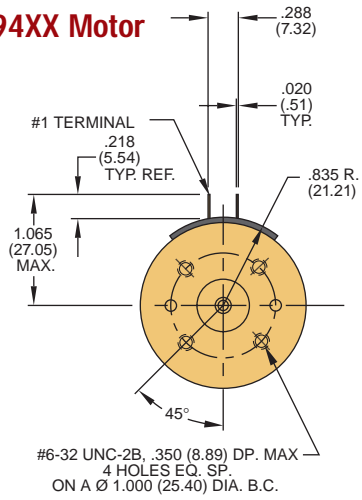

92XX Motor

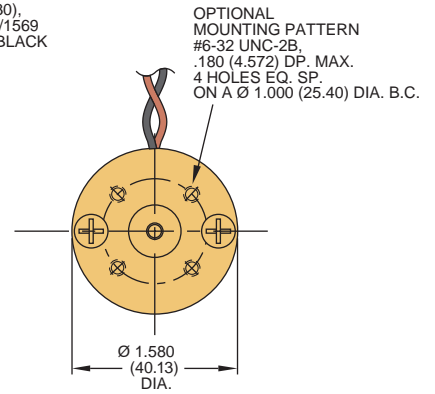
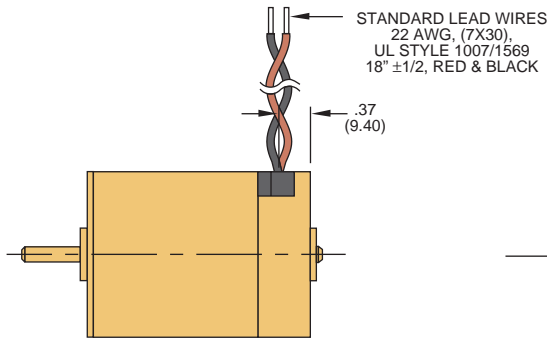
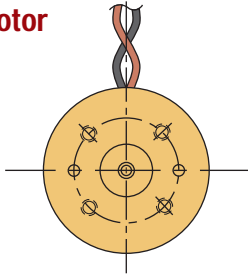

Notes:

- Unless otherwise specified, all tolerances are to be ±.005 (.01)
- All measurements are in inches (mm)
- *See line number 15 in motor data chart

**94XX Motor
with 91X0 Encoder**

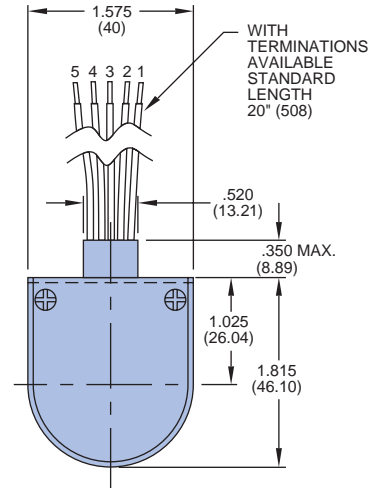
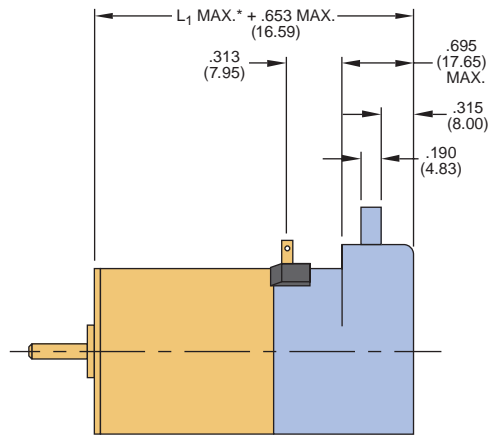
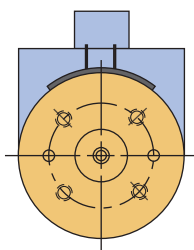

**92XX Motor
with 91X0 Encoder**

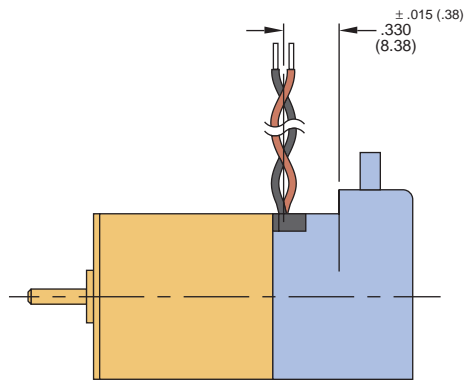
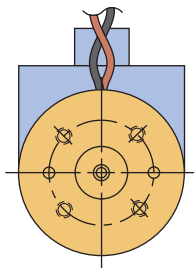

Encoder Connection Chart

Pin No.	Color	Connection
1	Black	Ground
2	Green	Index/NC
3	Yellow	Channel A
4	Red	Vcc
5	Blue	Channel B

Notes:

- Unless otherwise specified, all tolerances are to be $\pm .005$ (.01)
- All measurements are in inches (mm)
- *See line number 15 in motor data chart

SERIES 14000

Motor Data

Line No.	Parameter	Symbol	Units	14X01	14X02	14X03	14X04	14X05	14X06	14X07
1	Continuous Torque(Max.) ¹	T _C	oz-in (N-m)	10.0 (70.6 X 10 ⁻³)	14.0 (98.9 X 10 ⁻³)	21.0 (148.3 X 10 ⁻³)	26.0 (183.6 X 10 ⁻³)	31.0 (218.9 X 10 ⁻³)	36.5 (257.8 X 10 ⁻³)	50.0 (353.1 X 10 ⁻³)
2	Peak Torque (Stall) ²	T _{PK}	oz-in (N-m)	62.8 (.44)	107 (.76)	159 (1.12)	204 (1.44)	225 (1.59)	284 (2.01)	410 (2.90)
3	Motor Constant	K _M	oz-in/√W (N-m/√W)	4.45 (31.4 X 10 ⁻³)	5.93 (41.9 X 10 ⁻³)	7.88 (55.6 X 10 ⁻³)	8.63 (60.9 X 10 ⁻³)	9.97 (70.4 X 10 ⁻³)	10.9 (77.0 X 10 ⁻³)	13.1 (92.5 X 10 ⁻³)
4	No-Load Speed	S _{NL}	rpm (rad/s)	4230 (443)	4087 (428)	3456 (362)	3702 (388)	3056 (320)	3216 (337)	3211 (336)
5	Friction Torque	T _F	oz-in (N-m)	1.20 (8.5 X 10 ⁻³)	1.20 (8.5 X 10 ⁻³)	1.60 (11.3 X 10 ⁻³)	1.60 (11.3 X 10 ⁻³)	2.00 (14.1 X 10 ⁻³)	2.00 (14.1 X 10 ⁻³)	2.20 (15.5 X 10 ⁻³)
6	Rotor Inertia	J _M	oz-in-s ² (kg-m ²)	1.6 X 10 ⁻³ (1.13 X 10 ⁻⁵)	2.3 X 10 ⁻³ (1.62 X 10 ⁻⁵)	3.0 X 10 ⁻³ (2.12 X 10 ⁻⁵)	3.7 X 10 ⁻³ (2.61 X 10 ⁻⁵)	4.4 X 10 ⁻³ (3.11 X 10 ⁻⁵)	5.2 X 10 ⁻³ (3.67 X 10 ⁻⁵)	6.7 X 10 ⁻³ (4.73 X 10 ⁻⁵)
7	Electrical Time Constant	τ _E	ms	0.91	1.47	1.64	1.58	1.63	1.62	1.50
8	Mechanical Time Constant	τ _M	ms	11.4	9.26	6.84	7.04	6.27	6.19	5.50
9	Viscous Damping— Infinite Source Impedance	D	oz-in/krpm (N-m/(rad/s))	0.17 (1.14 X 10 ⁻⁵)	0.17 (1.14 X 10 ⁻⁵)	0.18 (1.21 X 10 ⁻⁵)	0.18 (1.21 X 10 ⁻⁵)	0.19 (1.28 X 10 ⁻⁵)	0.19 (1.28 X 10 ⁻⁵)	0.25 (1.69 X 10 ⁻⁵)
10	Viscous Damping— Zero Source Impedance	K _D	oz-in/krpm (N-m/(rad/s))	14.7 (9.91 X 10 ⁻⁴)	26.0 (1.75 X 10 ⁻³)	45.9 (3.09 X 10 ⁻³)	55.0 (3.71 X 10 ⁻³)	73.5 (4.96 X 10 ⁻³)	88.0 (5.93 X 10 ⁻³)	127.0 (8.56 X 10 ⁻³)
11	Maximum Winding Temperature	θ _{MAX}	°F (°C)	311 (155)	311 (155)	311 (155)	311 (155)	311 (155)	311 (155)	311 (155)
12	Thermal Impedance	R _{TH}	°F/watt °C/watt	49.8 (9.90)	48.2 (9.00)	46.6 (8.10)	45.9 (7.70)	45.1 (7.30)	44.2 (6.80)	41.0 (4.98)
13	Thermal Time Constant	τ _{TH}	min	22.0	24.0	26.0	28.8	29.4	33.6	32.3
14	Motor Weight	W _M	oz (gm)	20.8 (589.7)	26.0 (737.1)	31.2 (884.5)	35.2 (997.9)	39.5 (1119.8)	45.4 (1287.1)	54.5 (1545.1)
15	Motor Length, 1410X, 1420X	L ₁	in max (mm max)	2.953 (75.0)	3.203 (81.4)	3.703 (94.1)	4.078 (103.6)	4.453 (113.1)	4.953 (125.8)	5.703 (144.9)

Model 14X01/14X02 Winding Data (Other windings available upon request)

Line No.	Parameter	Symbol	Units	14X01				14X02			
16	Reference Voltage	E	V	12.0	19.1	24.0	30.3	12.0	19.1	24.0	30.3
17	Torque Constant	K _T	oz-in/A (N-m/A)	3.72 (26.3 X 10 ⁻³)	5.89 (41.6 X 10 ⁻³)	7.44 (52.5 X 10 ⁻³)	9.46 (66.8 X 10 ⁻³)	3.90 (27.5 X 10 ⁻³)	6.16 (43.5 X 10 ⁻³)	7.80 (55.1 X 10 ⁻³)	9.85 (69.6 X 10 ⁻³)
18	Back-EMF Constant	K _E	V/krpm (V/rad/s)	2.75 (26.3 X 10 ⁻³)	4.36 (41.6 X 10 ⁻³)	5.50 (52.5 X 10 ⁻³)	6.99 (66.8 X 10 ⁻³)	2.88 (27.5 X 10 ⁻³)	4.55 (43.5 X 10 ⁻³)	5.77 (55.1 X 10 ⁻³)	7.29 (69.6 X 10 ⁻³)
19	Resistance	R _T	Ω	0.72	1.76	2.79	4.45	0.45	1.09	1.73	2.74
20	Inductance	L	mH	0.63	1.59	2.54	4.10	0.63	1.58	2.54	4.05
21	No-Load Current	I _{NL}	A	0.52	0.33	0.26	0.20	0.49	0.31	0.24	0.19
22	Peak Current (Stall)	I _P	A	16.7	10.8	8.60	6.80	26.4	17.5	13.9	11.1

¹Continuous torque specified at 25°C ambient temperature and without additional heat sink.

²Theoretical values supplied for reference only.

Model 14X03/14X04 Winding Data (Other windings available upon request)

Line No.	Parameter	Symbol	Units	14X03				14X04			
23	Reference Voltage	E	V	12.0	19.1	24.0	30.3	12.0	19.1	24.0	30.3
24	Torque Constant	K_T	oz-in/A (N-m/A)	4.63 (32.7 X 10 ⁻³)	7.41 (52.3 X 10 ⁻³)	9.26 (65.4 X 10 ⁻³)	11.7 (82.6 X 10 ⁻³)	4.33 (30.7 X 10 ⁻³)	6.86 (48.5 X 10 ⁻³)	8.67 (61.2 X 10 ⁻³)	10.8 (76.5 X 10 ⁻³)
25	Back-EMF Constant	K_E	V/krpm (V/rad/s)	3.42 (32.7 X 10 ⁻³)	5.48 (52.3 X 10 ⁻³)	6.85 (65.4 X 10 ⁻³)	8.67 (82.6 X 10 ⁻³)	3.21 (30.7 X 10 ⁻³)	5.08 (48.5 X 10 ⁻³)	6.41 (61.2 X 10 ⁻³)	8.01 (76.5 X 10 ⁻³)
26	Resistance	R_T	Ω	0.37	0.89	1.38	2.19	0.27	0.65	1.01	1.57
27	Inductance	L	mH	0.56	1.45	2.26	3.63	0.40	1.00	1.60	2.50
28	No-Load Current	I_{NL}	A	0.48	0.30	0.24	0.19	0.52	0.33	0.26	0.21
29	Peak Current (Stall)	I_p	A	32.7	21.5	17.4	13.9	43.7	29.6	23.8	19.2

Model 14X05/14X06 Winding Data (Other windings available upon request)

Line No.	Parameter	Symbol	Units	14X05				14X06			
30	Reference Voltage	E	V	12.0	19.1	24.0	30.3	12.0	19.1	24.0	30.3
31	Torque Constant	K_T	oz-in/A (N-m/A)	5.25 (37.1 X 10 ⁻³)	8.31 (58.7 X 10 ⁻³)	10.5 (74.2 X 10 ⁻³)	13.1 (92.7 X 10 ⁻³)	4.74 (33.5 X 10 ⁻³)	7.89 (55.8 X 10 ⁻³)	10.0 (70.6 X 10 ⁻³)	12.6 (89.2 X 10 ⁻³)
32	Back-EMF Constant	K_E	V/krpm (V/rad/s)	3.88 (37.1 X 10 ⁻³)	6.15 (58.7 X 10 ⁻³)	7.76 (74.2 X 10 ⁻³)	9.71 (92.7 X 10 ⁻³)	3.50 (33.5 X 10 ⁻³)	5.84 (55.8 X 10 ⁻³)	7.39 (70.6 X 10 ⁻³)	9.34 (89.2 X 10 ⁻³)
33	Resistance	R_T	Ω	0.30	0.71	1.11	1.73	0.22	0.54	0.84	1.32
34	Inductance	L	mH	0.45	1.13	1.81	2.83	0.31	0.85	1.36	2.17
35	No-Load Current	I_{NL}	A	0.49	0.31	0.25	0.20	0.56	0.33	0.26	0.21
36	Peak Current (Stall)	I_p	A	40.1	27.0	21.6	17.5	54.2	35.6	28.6	23.0

Model 14X07 Winding Data (Other windings available upon request)

Line No.	Parameter	Symbol	Units	14X07							
37	Reference Voltage	E	V	15.1		19.1		24.0		30.3	
38	Torque Constant	K_T	oz-in/A (N-m/A)	6.0 (42.4 X 10 ⁻³)		8.0 (56.5 X 10 ⁻³)		10.0 (70.6 X 10 ⁻³)		12.7 (89.7 X 10 ⁻³)	
39	Back-EMF Constant	K_E	V/krpm (V/rad/s)	4.44 (42.4 X 10 ⁻³)		5.92 (56.5 X 10 ⁻³)		7.39 (70.6 X 10 ⁻³)		9.37 (89.7 X 10 ⁻³)	
40	Resistance	R_T	Ω	0.24		0.39		0.59		0.90	
41	Inductance	L	mH	0.31		0.56		0.87		1.40	
42	No-Load Current	I_{NL}	A	0.51		0.38		0.30		0.24	
43	Peak Current (Stall)	I_p	A	62.4		49.3		40.4		32.6	

Model 14X01

Motor Speed & Current vs. Torque
(24V Winding)

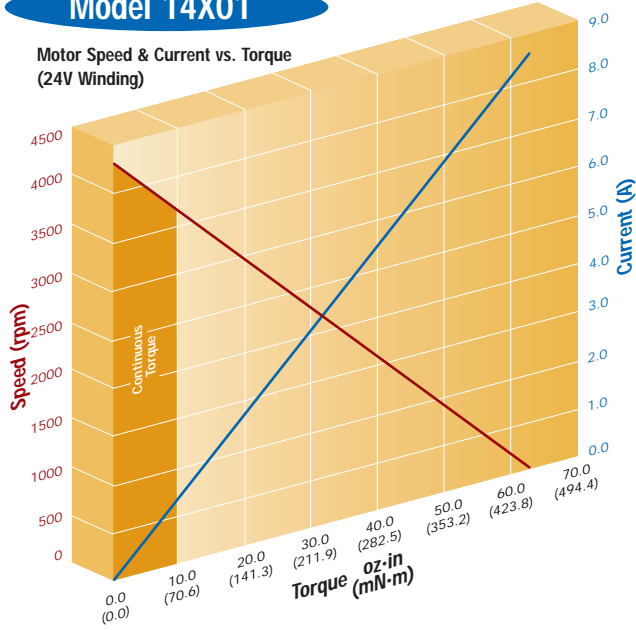

Model 14X02

Motor Speed & Current vs. Torque
(24V Winding)

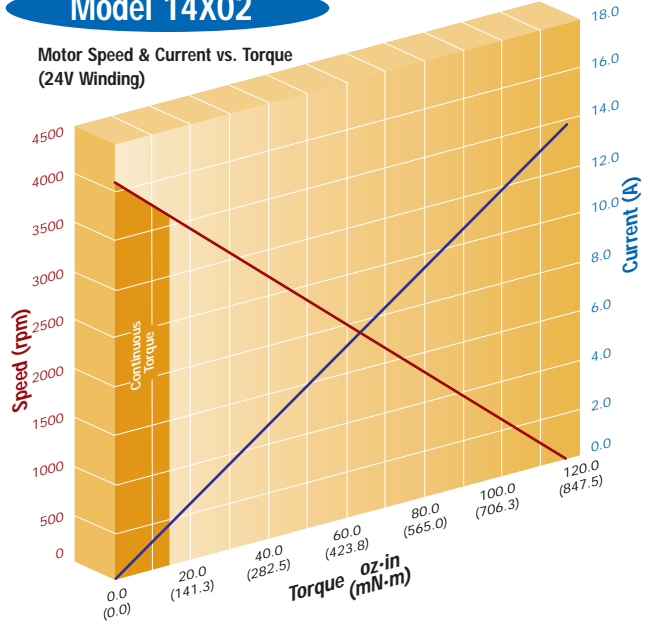

Model 14X03

Motor Speed & Current vs. Torque
(24V Winding)

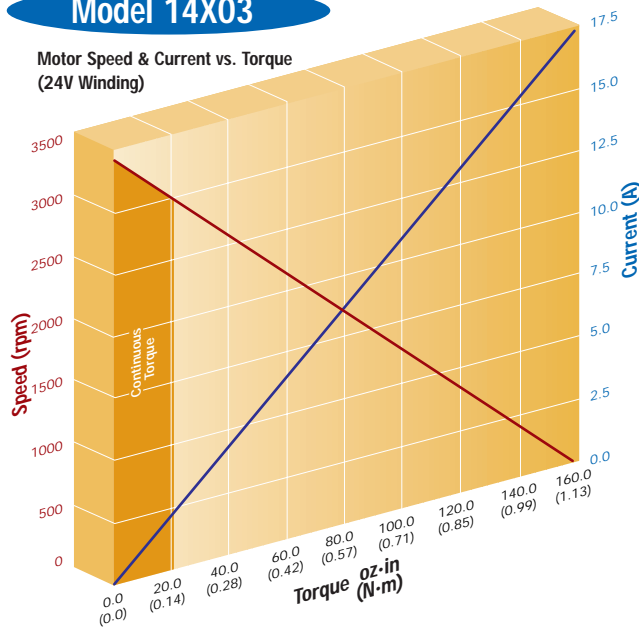

Model 14X04

Motor Speed & Current vs. Torque
(24V Winding)

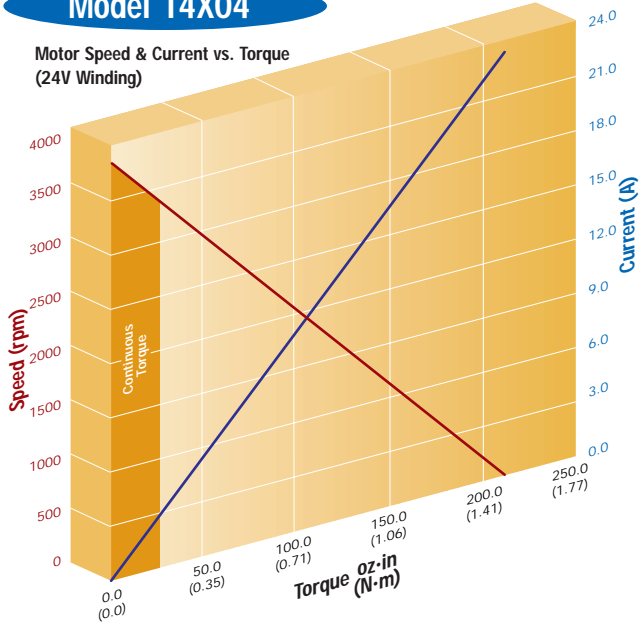

Model 14X05

Motor Speed & Current vs. Torque
(24V Winding)

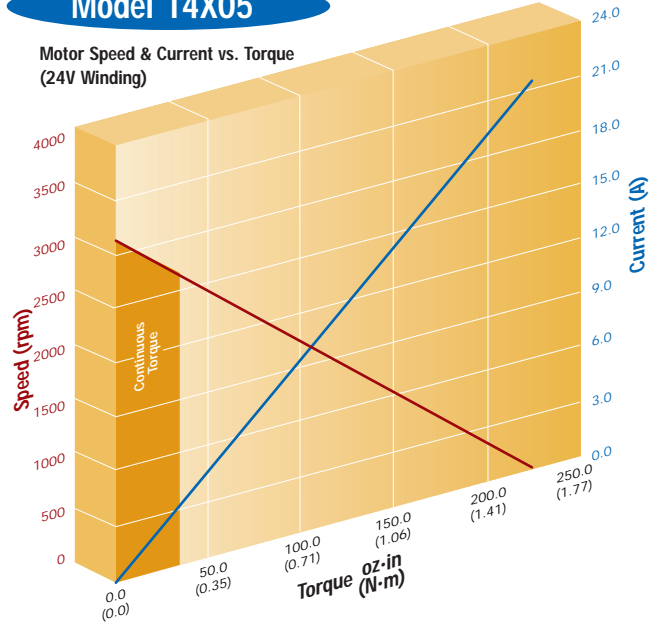

Model 14X06

Motor Speed & Current vs. Torque
(24V Winding)

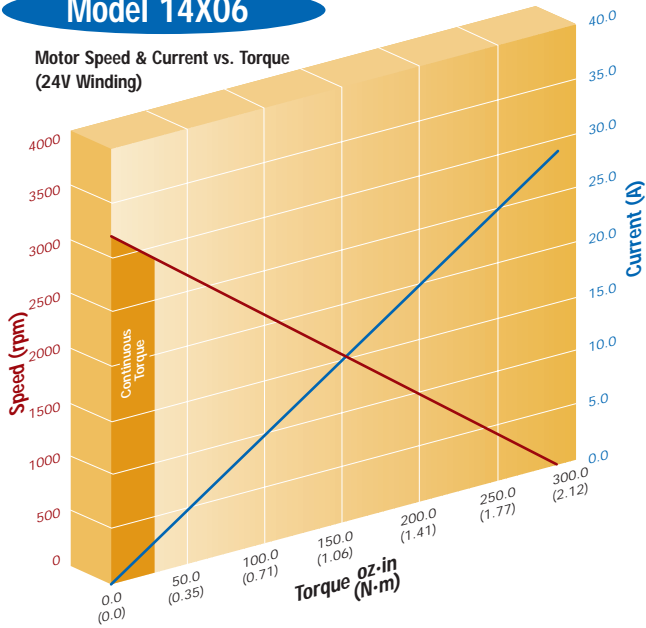

Model 14X07

Motor Speed & Current vs. Torque
(24V Winding)

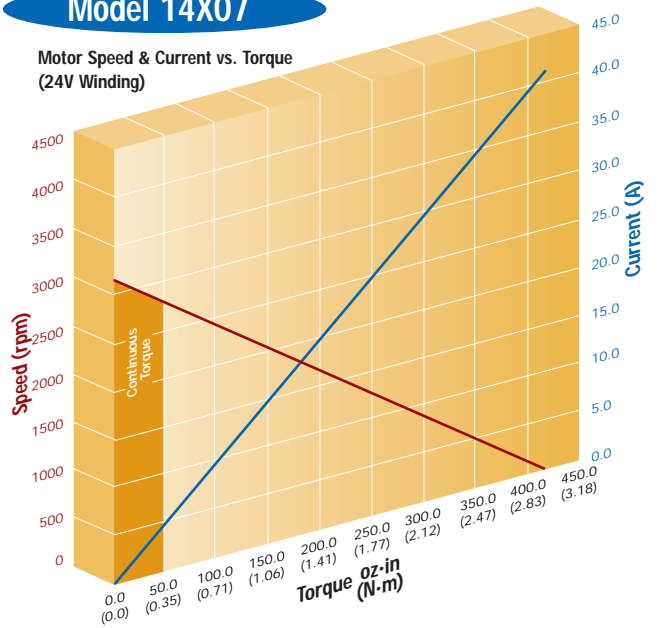

141XX/142XX Motor with 91X0 Encoder

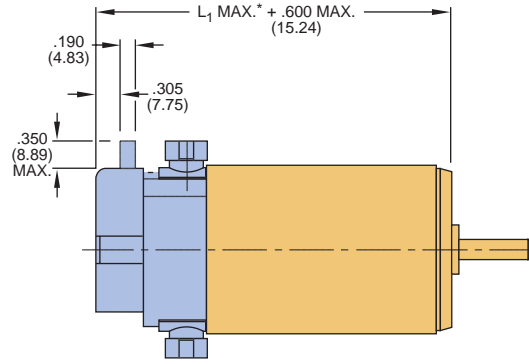
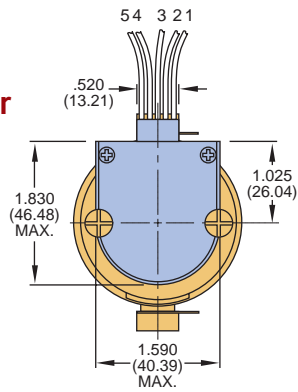

141XX/142XX Motor with 90X0 Encoder

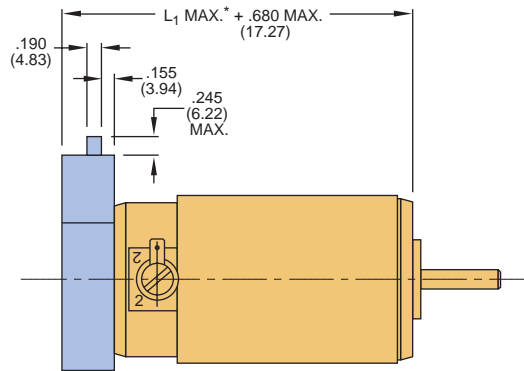
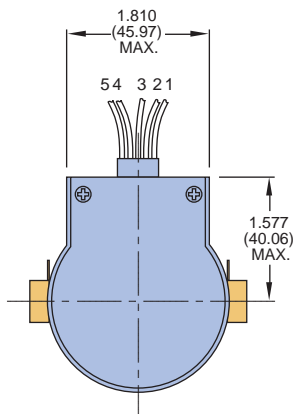

Encoder Connection Chart

Pin No.	Color	Connection
1	Black	Ground
2	Green	Index/NC
3	Yellow	Channel A
4	Red	Vcc
5	Blue	Channel B

Notes:

- Unless otherwise specified, all tolerances are to be $\pm .005$ (.01)
- All measurements are in inches (mm)
- *See line number 15 in motor data chart

14X3X Motor

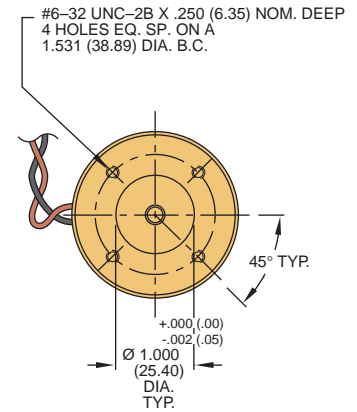
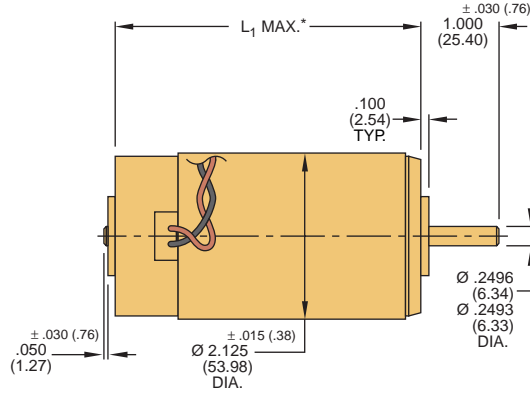
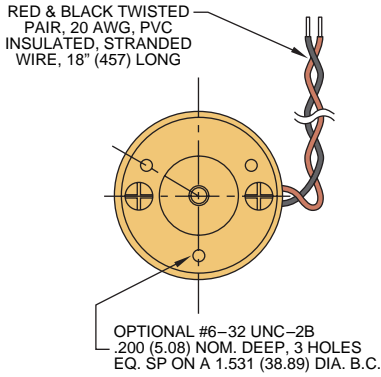

14X3X Motor with 91X0 Encoder

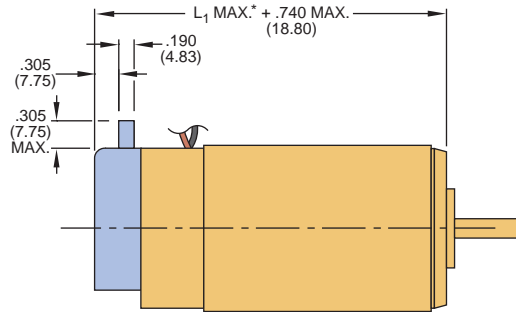
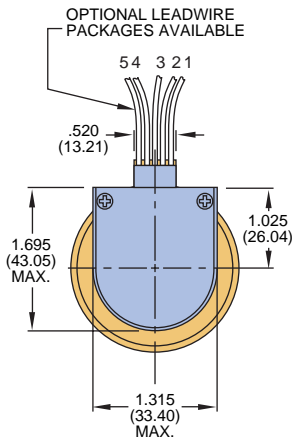

14X3X Motor with 90X0 Encoder

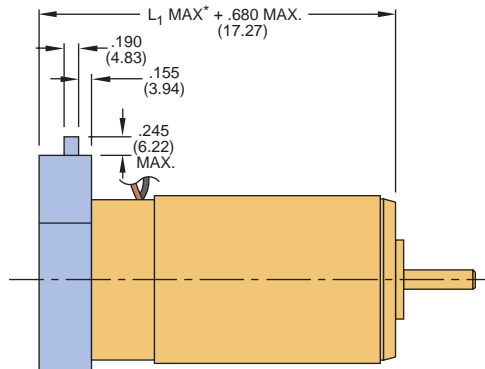
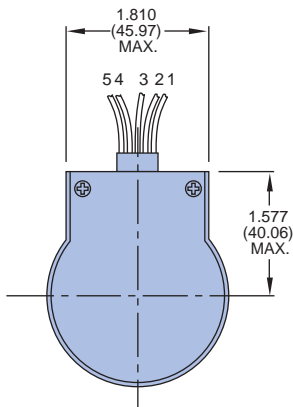

Encoder Connection Chart

Pin No.	Color	Connection
1	Black	Ground
2	Green	Index/NC
3	Yellow	Channel A
4	Red	Vcc
5	Blue	Channel B

Notes:

- Unless otherwise specified, all tolerances are to be $\pm .005$ (.01)
- All measurements are in inches (mm)
- *See line number 15 in motor data chart

PITTMAN[®]

343 GODSHALL DRIVE
 HARLEYSVILLE, PENNSYLVANIA 19438 U.S.A.
 PHONE: 215-256-6601 • FAX: 215-256-1338
 TOLL FREE: 877-PITTMAN (USA Only)
 E-MAIL: info@pittmannel.com
 WEB SITE: www.pittmannel.com

Specifications subject to change without notice.

